

Catalog Number 22-204A

MICRONTA[®]

50,000 OHMS/VOLT MULTITESTER
with Range Doubler

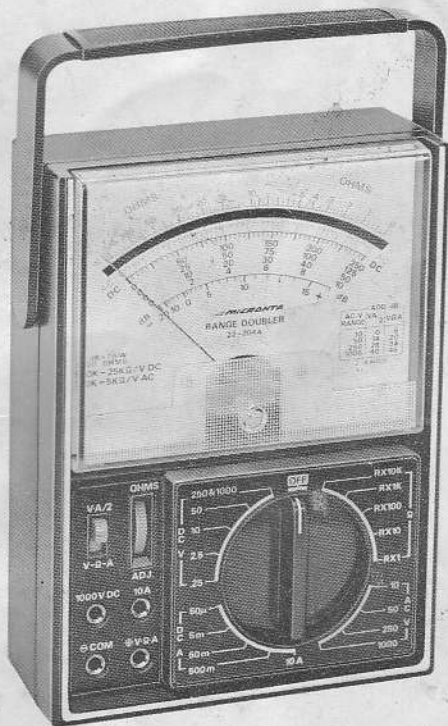

OPERATING INSTRUCTIONS

CUSTOM MANUFACTURED FOR

RADIO SHACK  A TANDY CORPORATION COMPANY

This high-sensitivity MICRONTA Multitester is designed to measure AC and DC voltages, DC current and Resistance with accuracy and ease. The large, single-knob Range/Function control is easy to use and read. The Range Doubler switch (V·A/2 - V-Ω-A) effectively doubles the number of AC and DC scales available. This means you can obtain meter readings in the upper half of the scale, resulting in consistent accuracy. An "OFF" position is provided to insure meter protection during transit.

The sensitive 15 μ A meter movement with 4¼" face and mirrored scale makes accurate reading a simple matter. The meter scales are in 3 colors for rapid identification. The lowest DC ranges - 125 mV and 25 μ A - are great for solid-state circuit work. The handle can be flipped around to the back to support the meter at an easy-to-read angle.

These features combined with rugged design and quality parts insure you of many years of accurate measurements.

SPECIFICATIONS

RANGES	43
DC Voltage	0-125-250 mV-1.25-2.5-5-10-25-50-125-250-500-1000 volts
AC Voltage	0-5-10-25-50-125-250-500-1000 volts
DC Current	0-25-50 μ A-2.5-5-25-50-250-500 mA-5-10 amperes
Resistance	0-2K-20K-200K-2 Meg-20 Meg (center scale 10)
Decibels	-20 to +62 in 8 ranges
ACCURACY	±3% DC except as noted ±4% AC, and 125 mV to 2.5 volts, and 500 to 1000 volts DC ±3% of scale length on Resistance
SENSITIVITY	DC: 50,000 ohms/volt (V·A/2) or 25,000 ohms/volt (V-Ω-A) AC: 10,000 ohms/volt (V·A/2) or 5,000 ohms/volt (V-Ω-A)
METER MOVEMENT	4¼", 3-color, mirrored scale, 18 μ A full scale
BATTERIES	Requires one type "AA" penlight cell and one 9-volt rectangular type for Ohms function
LEADS	47" spring-steel, banana plug style

USING YOUR MULTITESTER

Remove the back of the Multitester and install the batteries. Be careful to observe battery polarity.

For most accurate readings, keep the meter laying flat on a non-metallic surface. Also, use a Range and Range Doubler switch setting that results in a reading in the upper 1/3rd of the meter scale.

If the pointer does not normally rest exactly over "0" at the left side of the scale, adjust the plastic screw in the lower center of the meter face to bring the needle to "0".

Always observe correct test lead polarity when making DC measurements: Black into \ominus COM and Red into the \oplus V- Ω -A (or 1000V or 10A) jacks.

Exercise extreme caution when measuring voltages of 150 and above.

When not in use, always leave the Range switch in the "OFF" position.

Use the Range Doubler switch as follows:

For Resistance readings, always use the V- Ω -A position.

When using the V-A/2 position for all other functions, divide the Range switch setting by 2 and read on an appropriate scale. For example: Range set to 250 AC V and V-A/2 -- the range is 125 volts (250 divided by 2) and you should read the red scale, following the 0 to 125 markings. Another example: leads in \ominus COM and 10A with Range set to 10A and V-A/2 -- the range is 5 amperes (10 divided by 2) and you should read the black scale, following the 0 to 50 markings.

DC VOLTAGE MEASUREMENTS

1. Plug the test leads into the correct jacks (Black into \ominus COM and Red into \oplus V- Ω -A).
2. Set Range switch to one of the DC V positions; it is best to start at the top and work down.
3. Connect the test probe tips to the circuit under test; be sure to observe correct polarity. Set Range and Range Doubler switches as required to obtain a meter reading in the upper 1/2 or 1/3rd of the scale.

4. Read the voltage on the black DC scales. If the Range Doubler switch is in the V·A/2 position, be sure to divide the Range switch setting by 2 and read on the appropriate scale.
5. For voltages between 250 and 1000, set Range switch to 250&1000 and plug the red test lead into the 1000 Volt DC Only jack. For voltages between 250 and 500, set the Range Doubler switch to (V·A/2) (the range is then 500 volts). For voltages between 500 and 1000, set the Range Doubler switch to V-Ω-A (the range is then 1000 volts).

NOTE: The 1000 Volt DC Only jack is for use only with DC voltages of 250 to 1000.

USE EXTREME CARE WHEN USING THESE HIGH-VOLTAGE RANGES.

AC VOLTAGE MEASUREMENTS

1. Plug the test leads into the correct jacks (black into ⊖COM and red into ⊕V-Ω-A).
2. Set Range switch to one of the AC V positions; it is best to start at the top and work down.
3. Connect the test probe tips to the circuit under test. Set Range and Range Doubler switches as required to obtain a meter reading in the upper 1/2 or 1/3rd of the scale.
4. Read the voltage on the red AC scale, following black numbers printed below the red scale. If the Range Doubler switch is in the V·A/2 position, be sure to divide the Range switch setting by 2 and read the appropriate scale.

RESISTANCE MEASUREMENTS

Before taking any resistance measurements, disconnect power to the unit under test and discharge capacitors. It is best to remove batteries and unplug line cords.

1. Plug the test leads into the ⊖COM and ⊕V-Ω-A jacks.
2. Leave the Range Doubler switch in the V-Ω-A position. Set Range switch to one of the Ω positions; touch the test probes together and adjust the OHMS ADJ. control to bring the pointer to the "0" on the top (green) OHMS scale.

3. Now, connect the probe tips across the circuit or part under test.
4. Read the resistance on the green OHMS scale; use the proper multiplier to obtain the correct value (R "times" 1, 10, 100, 1000 or 10,000, depending on the position of the Range switch).

NOTES: When you are unable to adjust the pointer to "0" on the OHMS scale in the R x 1, R x 10, R x 100 or R x 1K positions, the penlight battery must be replaced. When you are unable to adjust the pointer to "0" on the OHMS scale when in the R x 10K position, replace the 9-volt battery. When measuring resistance, it is best to disconnect one side of the part under test (thus the remainder of the circuit will not interfere with the readings).

THE RANGE DOUBLER SWITCH MUST BE LEFT IN THE V- Ω -A POSITION FOR ALL RESISTANCE MEASUREMENTS.

DC CURRENT MEASUREMENTS

1. Plug the test leads into the correct jacks (Black into \ominus COM and Red into \oplus V- Ω -A).
2. Set the Range switch to the 500m DC A position (500 milliamp). Or, if the current will be greater than 500 mA, use the 10A jack (instead of the \oplus V- Ω -A) and set Range to 10A. Always start at the top and work down.
3. Open up the circuit in which you want to measure current and connect the black lead to the negative side and the red lead to the positive side of the circuit.
4. Apply power to the circuit under test.
Set Range and Range Doubler switches as required to obtain a meter reading in the upper $\frac{1}{2}$ or $\frac{1}{3}$ rd of the scale.
5. Read the current on the black DC scales. If the Range Doubler switch is in the V-A/2 position, be sure to divide the Range switch setting by 2 and read on the appropriate scale.

NOTES: Do not attempt to read AC current. For currents above 500 milliamps, use the 10A Range switch setting and the 10A jack (instead of the \oplus V- Ω -A jack). Use the appropriate setting of the Range Doubler switch.

DECIBEL MEASUREMENTS

1. Plug the test leads into the correct jacks (Black into \ominus COM and Red into \oplus V- Ω -A).
2. Set the Range and Voltage Doubler switches as required to obtain a meter reading in the upper $\frac{1}{2}$ of the scale.
3. Read dB on the DB scale, adding the appropriate number of dB to the DB scale reading as noted on the chart at the lower right on the meter face.

NOTE: For absolute dB measurements, circuit impedance must be 600 ohms.
0 dB = 1 milliwatt dissipated in a 600 ohm impedance (equivalent to 0.775 volts across 600 ohms).

SCHEMATIC DIAGRAM

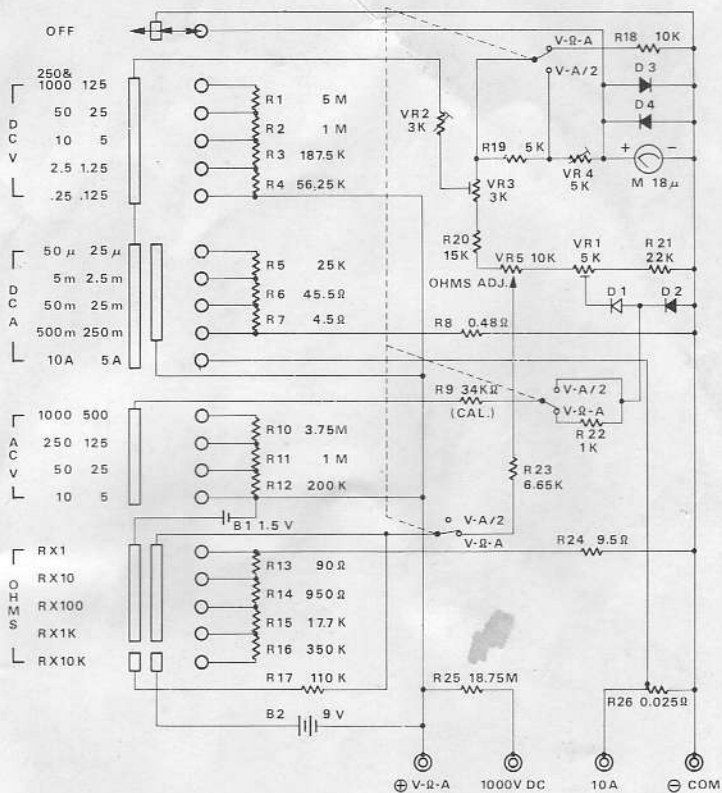

RADIO SHACK  A TANDY CORPORATION COMPANY
FORT WORTH, TEXAS 76107

Printed in Korea